

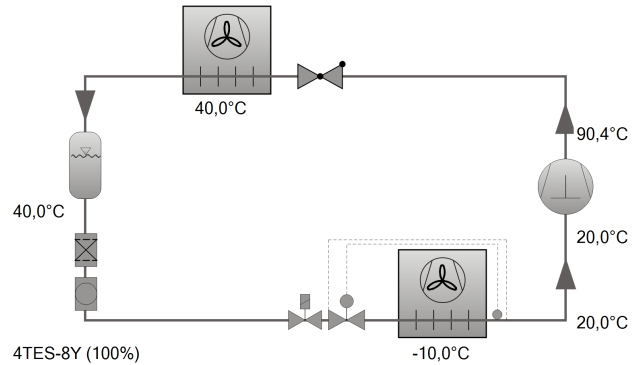

Selection: Semi-hermetic Reciprocating Compressors

Input Values

Compressor model	4TES-8Y
Mode	Refrigeration and air conditioning
Refrigerant	R134a
Reference temperature	Dew point temp.
Evaporating SST	-10,00 °C
Condensing SDT	40,0 °C
Liq. subc. (in condenser)	0 K
Suction gas temperature	20,00 °C
Operating mode	Auto
Power supply	400V-3-50Hz
Capacity control	100%
Useful superheat	100%



Result

Compressor	4TES-8Y-40P
Capacity steps	100%
Cooling capacity	13,42 kW
Cooling capacity *	13,42 kW
Evaporator capacity	13,42 kW
Power input	4,68 kW
Current (400V)	8,99 A
Voltage range	380-420V
Condenser capacity	18,10 kW
COP/EER	2,87
COP/EER *	2,87
Mass flow	299 kg/h
Operating mode	Standard
Discharge gas temp. w/o cooling	90,4 °C

Tentative Data.

Please consider design current for 70 Hz operation when using a frequency inverter! See also KP-100.

*According to EN12900 (20°C suction gas temp., 0K liquid subcooling)

Application Limits 100% 4TES-8

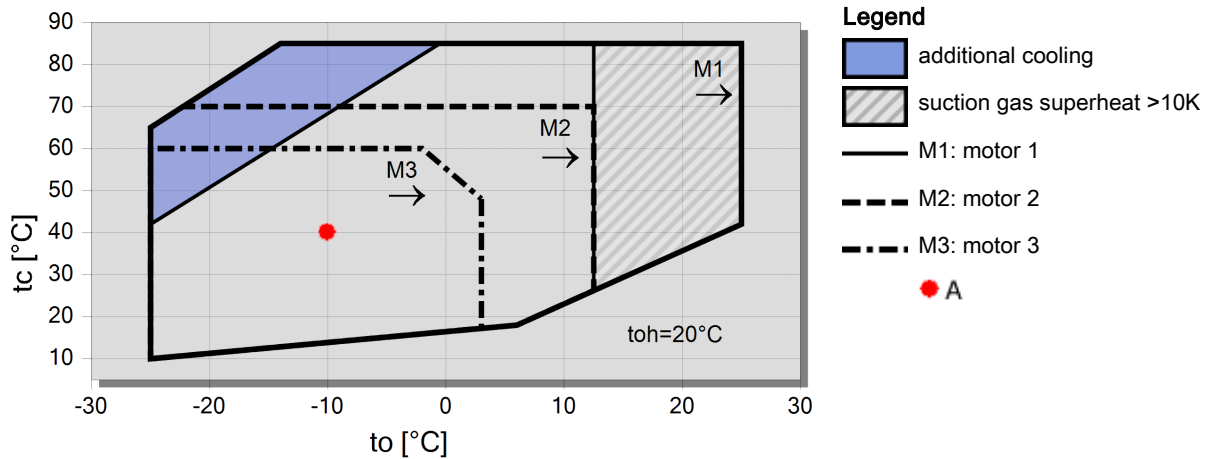



Technical Data: 4TES-8Y

Dimensions and Connections

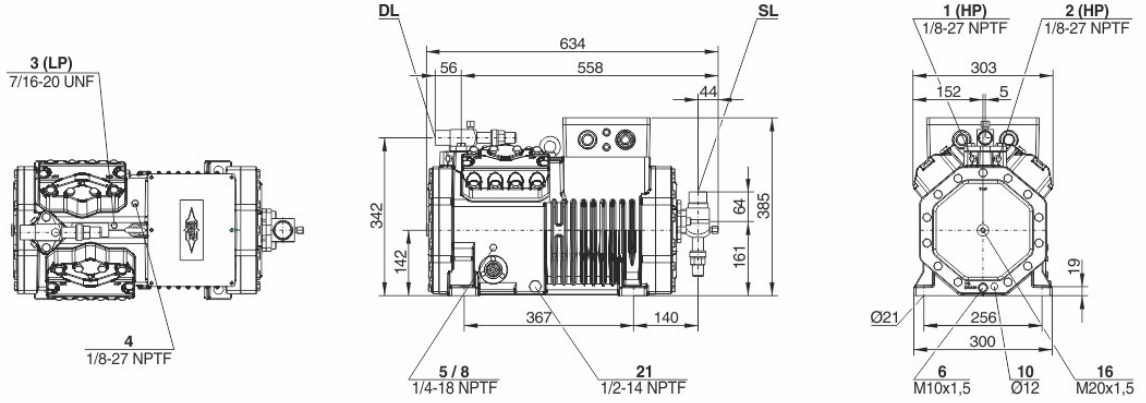



Technical Data

Technical Data

Displacement (1450rpm 50Hz)	41,33 m ³ /h
Displacement (1750rpm 60Hz)	49,88 m ³ /h
Frequency range	25..70 Hz
No. of cylinder x bore x stroke	4 x 60 mm x 42 mm
Weight	143 kg
Max. pressure (LP/HP)	19 / 32 bar
Connection suction line	35 mm - 1 3/8"
Connection discharge line	28 mm - 1 1/8"
Oil type R134a/R407C/R404A/R507A/R407A/R407F	BSE32(Standard) R134a tc>70°C: BSE55 (Option)
Oil type R1234yf	BSE32 (Standard) R1234yf tc>70°C : BSE55 (Option)
Oil type R1234ze	BSE55 (Standard) to>15°C: BSE85K (Option) tc>70°C: BSE85K (Option)
Oil type R454C/R455A	BSE32 (Standard)

Motor data

Motor version	3
Motor voltage (more on request)	380-420V PW-3-50Hz
Max. operating current	12.1 A
Max. operating current 70Hz/400V/FI	17,6 A
Winding ratio	50/50
Starting current (Rotor locked)	49.0 A Y / 81.0 A YY
Max. power input	7,0 kW

Extent of delivery (standard)

Motor protection	SE-B3 (Option), SE-B2 (Option), CM-RC-02 (Standard)
Enclosure class	IP66
Vibration dampers	Standard
Oil charge	2,60 dm ³
Discharge shut-off valve	Standard
Suction shut-off valve	Standard

Available options

Discharge gas temperature sensor	Option
Start unloading	Option
Capacity control	100-50% (Option)
Capacity Control - infinite	100-10% (Option)
Additional fan	Option
Oil service valve	Option
Oil heater	0..140 W PTC (Option)
Oil level monitoring	OLC-K1 (Option)

Sound measurement

Sound power level (-10°C / 45°C)	72,3 dB(A) @50Hz
Sound pressure level @ 1m (-10°C / 45°C)	64,3 dB(A) @50Hz



Semi-hermetic Reciprocating Compressors

Motor 1 = e.g. 4TES-12 with 12"HP", primary for air-conditioning (e.g. R22,R407C) and air-conditioning with R134a at high ambient temperatures.

Motor 2 = e.g. 4TES-9 with 8"HP", universal Motor for medium and low temperature application (e.g. R404A, R507A, R407A, R407F) and air-conditioning with R134a

Motor 3 = e.g. 4TES-8, for medium temperature applications and R134a

For more information concerning the application range use the "Limits" button.

Operation modes 4VES-7 to 6FE-44 and 44JE-30 to 66FE-88 with R407F/R407A/R22

CIC = liquid injection with low temperature application, suction gas cooled motor.

ASERCOM certified performance data

The Association of European Refrigeration Component Manufacturers has implemented a procedure of certifying performance data. The high standard of these certifications is assured by:

- * plausibility tests of the data performed by experts.
- * regular measurements at independent institutes.

These high efforts result in the fact that only a limited number of compressors can be submitted. Due to this not all BITZER compressors are certified until now. Performance data of compressors which fulfil the strict requirements may carry the label "ASERCOM certified". In this software you will find the label at the respective compressors on the right side below the field "result" or in the print out of the performance data. All certified compressors and further information are listed on the homepage of ASERCOM.

Condensing capacity

The condensing capacity can be calculated with or without heat rejection. This option can be set in the menu Program Options. The heat rejection is constantly 5% of the power consumption. The condensing capacity is to be found in the line Condensing cap. (with HR) resp. Condensing capacity.

Data for sound emission

Data based on 50HZ application (IP-units 60Hz) and R404A if not declared.

Sound pressure level: values based on free field area conditions with hemispherical sound emission in 1 meter distance.

General remarks regarding sound data

Listed sound data were measured under testing conditions in our laboratory. For this purpose the free-standing test sample is mounted on a solid foundation plate and the pipework is connected vibration-free to the largest extent possible. Suction and discharge lines are fixed in a flexible configuration, such that a transmission of vibrations to the environment can be largely excluded. In real installations considerable differences might be observed, compared to the measurements in the laboratory. The airborne sound emitted by the compressor can be reflected from surfaces of the system and this may increase the airborne sound level measured close to the compressor. Vibrations caused by the compressor are also transferred to the system by the compressor feet and piping depending on the damping ratio of the fixings. Thus, the vibrations can induce other components to such an extent that these components contribute to an increase in airborne sound emission. If required, the transfer of vibrations to the system can be minimized by suitable fixing and damping elements.



Selection: Horizontal receivers

Input Values

Common	Yes
Auto	
Operating point	Auto

Operating points

	A
to [°C]	-10
tc [°C]	40

Result

Compressor:	4TES-8Y
Recommendation:	F252H
Selection	F252H
Recommended operating point:	A
Selected operating point:	A
Receiver volume	25,0 dm ³
Max. refrigerant charge	27,6 kg
Receiver load	81,2 %
Receiver unit	indivi. components
lower fixing rails	327301-05
upper fixing rails	327301-24
upper fixing plate	320366-02

#1: Receiver selection for compact systems without condensing pressure control. Precise calculation only via refrigerant charge (see notes).



Technical Data: F252H

Dimensions and Connections

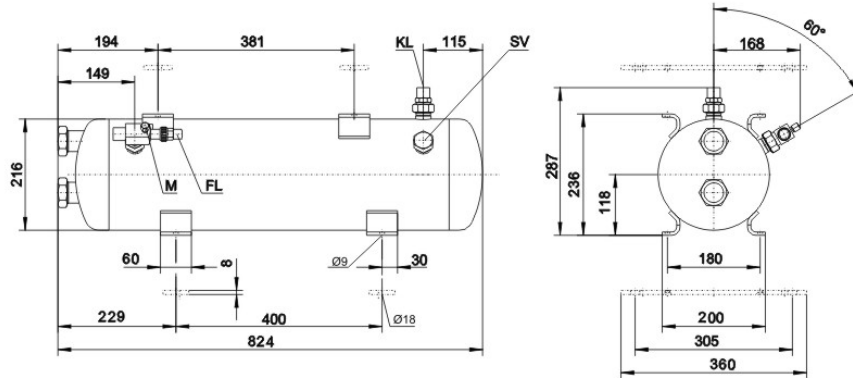



Technical Data

Technical Data	
Weight	23,6 kg
Total width	824 mm
Total depth	276 mm
Total height	287mm
Receiver volume refrigerant	25,0 l
Max. refrigerant charge 90% at 20°C / 68°F	
R22	27,2 kg
R134a	27,6 kg
R407C	26,1 kg
R404A/R507A	24,0 kg
R448A	25,0 kg
R449A	25,1 kg
R450A	26,8 kg
R454C	22,6 kg
R455A	23,4 kg
R513A	27,6 kg
R1234yf	25 kg
R1234ze	26,5 kg
R515B	26,9 kg
Max. pressure	33 bar
Max. operating temperature	120°C
Connection inlet KL	22mm - 7/8"
Connection thread/ -flange	1 1/4" - 12 UNF
Connection outlet FL	22mm - 7/8"
Connection thread/ -flange	1 1/4" - 12 UNF
Gauge	7/16" 20UNF
Connection for pressure relief valve	1 1/4"-12UNF
Adapter for pressure relief valve	Option
Minimum level control	Option
Maximum level control	Option
*According PED 2014/68/EU	Standard
Special Approvals (on request)	Option



Selection of the receivers:

1) "Approx. according to cooling capacity":

The receiver volume is determined by the design of the unit, the operating mode and the function of the receiver (receiving the complete refrigerant charge in the receiver or only compensating capacity variations). When selected via cooling capacity, an approximate selection of the receiver is obtained. Receivers in systems with long pipelines, winter control or in very compact systems should be selected according to method 2).

2) "According to refrigerant charge in the receiver":

The calculation is made on the basis of the specified refrigerant charge. The receiver volume is determined at 20°C and at a maximum filling charge of 95% of the possible receiver content.

Compressor units equipped with receiver

The BITZER range of products comprises compressor units with horizontal receivers. In the output window of the accessories these units, which are included in the standard delivery, are marked with "mounted" in the compressor unit line. Units that can be mounted, but are not included in the Bitzer delivery program, are marked with "single parts". Units in which the compressor does not fit onto the receiver are marked with "--".



Selection: IQ MODULE

Result

Quantity	Selection	Extent of delivery	Functionality
1	CM-RC-02/SE-B no basic module	CM-RC-02 mounted in module housing. Peripheral devices connected to module	Data logging of operating conditions, compressor start function (contactors), Modbus communication, Bluetooth



Technical Data: CM-RC-02

Dimensions and Connections

Drawing not found:



Technical Data

Electrical data

Operating voltage	115V-230V +10%/-10%
Required fuse	8A @ 115V / 4A @ 230V
Enclosure class for module housing of 4VES-6 .. 6FE-50	IP66
Enclosure class for module housing of 8GE-50 .. 8FE-70	IP66
Allowable ambient temperature	-30°C / 70°C
Maximum allowable altitude	4000m
Allowable relative humidity	5%-95%

Extent of delivery (standard)

Interfaces:

- Modbus RTU
- Bluetooth

Real-time clock

